

PATRIOT

M50

LA type soldering iron controller Instruction manual (QSS-4000)

Date prepared: March 2019

The 8th edition

JAPAN BONKOTE CO., LTD.



BONKOTE®

1	Preface	1
2	Notes for safety	1
3	Auto Tuning before use	1
4	Notes for installation and use	2
5	How to use M50 controller	
	(A) Contents	3
	(B) Name of the body	3
	(C) How to assemble	4
	(D) How to use	5
6	Optional function	
	(A) Alarm function upper limit setting	7
	(B) Alarm function lower limit setting	8
	(C) Temperature recovery speed setting	8
	(D) Upper limit setting of set temperature	8
	(E) Indication of manipulated output value	9
	(F) Lock function	9
	(G) Anti reset wind up setting	10
	(H) Auto Power Down / Auto Power Off setting	10
	(I) PID value manual setting	13
	(J) Device Number setting	14
7	List of character	15
8	How to maintenance	16
9	Standard specification	16
10	Guarantee and After sales service	
	(A) Trouble shooting	17
	(B) Guarantee	17
	(C) After sales service	17

1. Preface

Thank you very much for purchasing M50 CONTROLLER.

Please read this Notes for safety before use, and use this machine properly.

After read this manual, please keep it.

2. Notes for safety



CAUTION

Be sure to read this manual before using this machine.

- Never touch the power cord and the soldering iron with dump hands. Otherwise, you may get hurt due to electric shock and etc. (death at worse)
- Never dampen the iron tip with water or other liquid. Otherwise, burst cord may cause fire, malfunction, electric shock and etc. (death at worse)
- Take great care to handle the soldering iron while it is not rested on the workbench. Otherwise, the heated tip may cause fire or adjacent operations may get hurt.
- Unplug the iron unit and allow sufficient time for it to cool when replacement or maintenance.
- Do not overhaul the machine when the machine has trouble. Otherwise, it may cause malfunction, electric shock and etc. (death at worse) Contact our customer service department and follow instructions to make maintenance.
- Be sure to use proper replacement parts such as fuse, checking capabilities. Otherwise, parts with wrong capacities may cause fire, malfunction and tec.

3. Auto Tuning before use

We would recommend Auto Tuning before use, although each parameter is set in the standard value at the shipment. By doing so, soldering irons will perform with good effect according to iron tip temperature, shape of iron tip, working environments and so on.

※ This function will be set automatically by keypad. (Please refer to P.7)

4. Notes for installation and use

- This machine is designed with earth specification. Make sure to use an earth equipped receptacle. If you do not have such receptacle, install an earth separately.
- Use this machine on a neat bench on which a conducive mat is put.
- Do not place where the machine would be exposed too much moisture, direct sunshine, much dust and vibration.
- In order to prevent static electricity, we recommend that you use a static electricity removal device, wrist strap etc.
- Odor is generated due to the use of solder and flux. Be sure to ventilate work places. e.g. Install a ventilation fan etc.
- Be sure to pull out the power plug when the machine is not used.
- Be sure to grab the power plug instead of the cord, when plugging and unplugging.
- When change power voltage from 100V to 220V for example, make sure to confirm the specifications of the soldering iron before use.
- Please keep flammable objects away from this machine.
- Be sure to check the slack of each screw and tighten them securely before use this machine.
- Do not use this machine for purpose other than the original purpose.

5. How to use

5-A : Contents of soldering station set



- ① 3P Power cord ※
- ② M50 Controller
- ③ BON-11 Iron stand
- ④ TB-170J Soldering iron

NOTE:

This picture is M50-TB-170J station set.

※ 3PCHI plug cord for 100V, or 3EPV plug cord for 220V comes with a controller.

5-B : Name of the body

《 FRONT 》



《 BACK 》



- ① Power switch
- ② 5 pin connector
- ③ PV display (working temperature)
- ④ SV display (setting temperature)
- ⑤ △ key (value up)
- ⑥ ▽ key (value down)
- ⑦ ○ key (function key)
- ⑧ □ key (speed setting)
- ⑨ Fuse holder
- ⑩ 3 pin inlet
- ⑪ Modular jack

5-C : How to assemble



- ① Insert the power cord into the 3 pin inlet at the back face.
- ② Connect the soldering iron to 5 pin connector at the front, and turn the connector housing clockwise to lock it in place.
- ③ Assemble the iron stand and store the soldering iron in its holder ①.

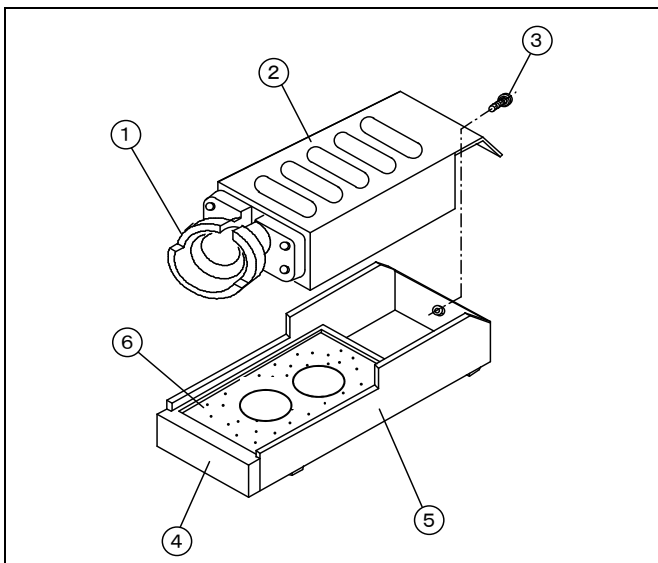

No.	Name	Model No.
1	Holder	B-11
2	Cover	—
3	Screw with spring-washer	M4 x 6
4	Cleaner case	K-5
5	Cleaner base	—
6	Cleaning sponge	S-6

Assemble order

- I : Remove the screw ③ from the cleaner base ⑤.
- II : Align a screw hole of the holder ① and the cleaner base ⑤, then tighten the screw.

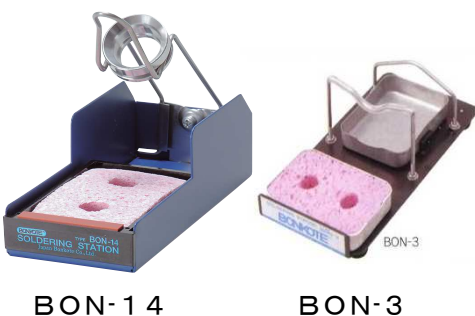

Iron stand BON-14 is for TB-1175/2175 iron,
BON-3 is for TB-1100/2100.

5-D : How to use

① Turn on power

Insert the power plug into the receptacle. Confirm each input voltage of the soldering iron and the controller is the same, then turn on the power.

※ Do not use a 100V soldering iron with 220V power source. Failure to do so may damage the heater.

② Setting and confirmation of the sensor type

M50 Controller is workable for 2 different kinds of soldering iron, one is type J sensor and the other type K sensor. Please make sure that the each sensor type of the soldering iron and that of the controller should be the same. Otherwise temperature control is unable to work.

※ The sensor type of controller and soldering iron is adjusted the same at the shipment.
The sensor type of controller itself is type K at the shipment.

②-1 How to confirm the sensor type.

- Controller part

At the operation mode, K or J is indicated at SV display as show below.

Check the sensor type of the controller whether it is the same as that of a connected soldering iron.



《 Type K 》



《 Type J 》

- Soldering iron

There are 2 different kinds of sensor type, which are type J and type K.

Please check the label of the soldering iron.

Type J soldering iron has a capital letter "J" as below.

TYPE K soldering iron



TYPE J soldering iron



②-2 How to set the sensor type

I : At the operation mode, press \bigcirc key approx. 3 seconds while pressing ∇ key.

$\hookrightarrow \text{E} \hookrightarrow$ is indicated at PV display.

II : Enter suitable sensor type by Δ key or ∇ key, then push \bigcirc key 7 times to return to the operation mode.

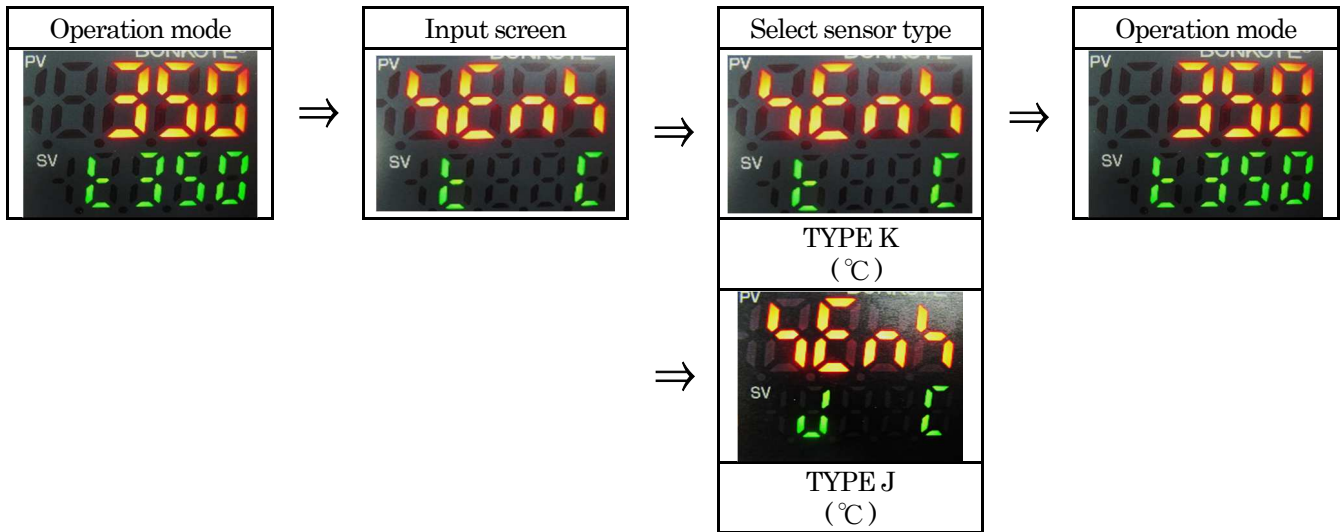

③ Set the set temperature

Default : 350°C

Setting range : 0 ~ 500°C

Default : 200°C

※ when 「BNJT7」 type iron tip equipped.

I : At the operation mode, press \bigcirc key once, and \hookrightarrow is indicated at PV display.

II : Enter the desired temperature by Δ key or ∇ key.

III : Press \bigcirc key once to return to the operation mode.

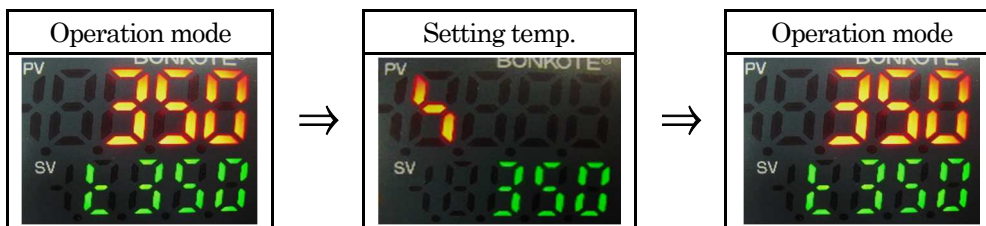

④ Temperature compensation

Default : 0°C

Setting range : -100.0°C ~ 100.0°C

I : At the operation mode, press \bigcirc key approx.3 seconds while pressing ∇ key.

$\hookrightarrow \text{E} \hookrightarrow$ is indicated at PV display.

II : Press \bigcirc key 3 times, and $\hookrightarrow \text{E} \hookrightarrow$ is indicated at PV display.

III : Enter the desired value by Δ key or ∇ key at SV display.

IV : After entering the value, push \bigcirc key 4 times to return to the operation mode.

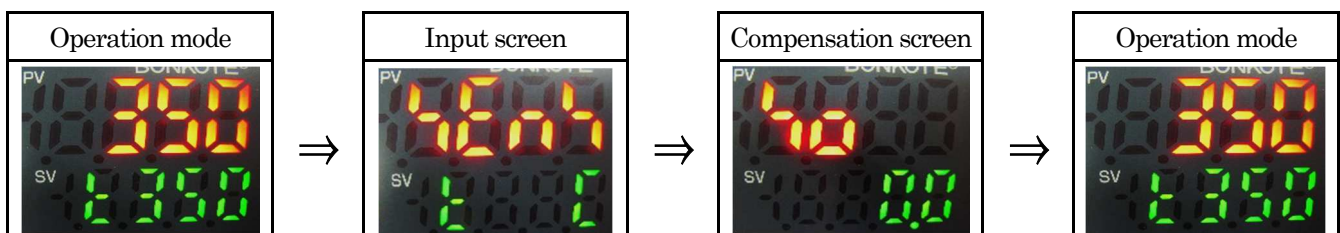

How to calculate the compensation value with a standard thermometer.

e.g. : Thermometer value: 「350°C」 Controller value : 「355°C」 Compensation value is 「-5」

Compensation value = Thermometer value - Controller value \Rightarrow 「350」 - 「355」 = 「-5」

⑤ Start Auto Tuning *after reach to the set temperature*

- I : At the operation mode, press ○ key for 3 seconds while pressing △ key, and AT is indicated at PV display.
- II : Push △ key once, and AT is indicated at SV display, too.
- III : Push ○ key to start Auto Tuning. (“AT” lamp starts blinking.)
Auto Tuning function completes in about 2 minutes. (“AT” lamp stops blinking.)

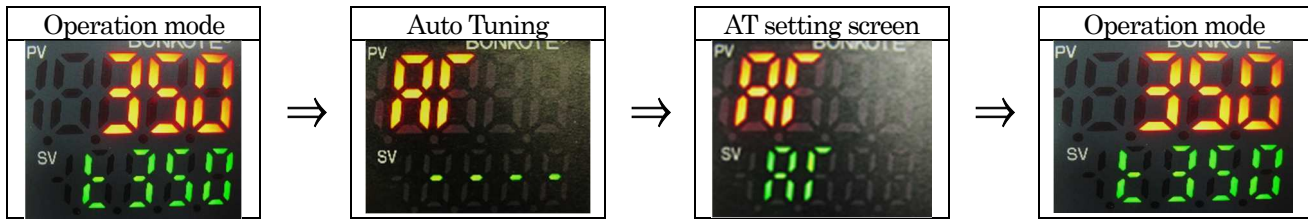

Auto Tuning function automatically calculates the suitable PID value which controls soldering irons. Make sure to implement Auto Tuning function to make soldering irons perform with enough effect.



After reach to the set temperature, please implement Auto Tuning function.

Do not touch the soldering iron in operation.

The fluctuation in temperature of soldering iron automatically calculates PID value. Thus, touching the soldering iron in operation causes incorrect PID value calculation and the soldering iron may not perform with enough effect. Auto Tuning completes when “AT” lamp stops blinking.

Above ④ and ⑤ are unnecessary to do every time. Do it when iron tips or set temperature are changed.

※ At shipment, Auto Tuning function has NOT done yet. Make sure to do it at the first time to use.

6. Optional functions

M50 controller has various functions. Please use them with your convenience.

6-A : Alarm function Upper limit setting

Set the upper limit of operation temperature range

Default : 0 °C

- I : At the operation mode, press ○ key for 3 seconds while pressing △ key, and AT is indicated at PV display.
- II : Push ○ key 5 times, and AL is indicated at PV display.
- III : Enter the desired value by △ or ▽ key at SV display. Push ○ key 2 times to return to the operation mode.

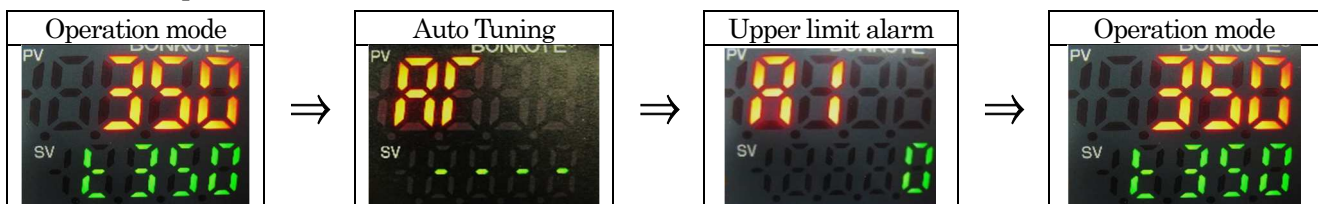

This function can alarm when the operation temperature exceeds the upper limit you set up.

e.g. Controller set temperature: 「350°C」 and Upper limit temperature: 「100°C」

When the operating temperature exceeds 「450°C」 at above condition, it will work.

6-B : Alarm function Lower limit setting

Set the lower limit of operation temperature range

Default : 0 °C

I : At the operation mode, press \bigcirc key for 3 seconds while pressing \triangle key, and FF is indicated at PV display.

II : Push \bigcirc key 6 times, and FL is indicated at PV display.

III : Enter the desired value by \triangle or ∇ key at SV display, then push \bigcirc key 1 times to return to the operation mode.

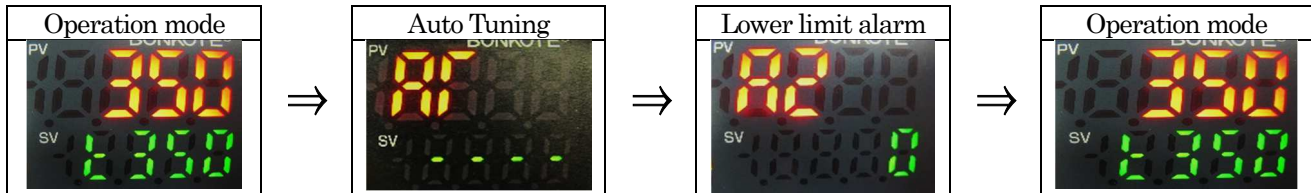

This function can alarm when the operation temperature exceeds the lower limit you set up.

e.g. Controller set temperature: 「350°C」 and Upper limit temperature: 「-100°C」

When the operating temperature exceeds 「-250°C」 at above condition, it will work.

6-C : Temperature Recovery speed

Adjust the recovery speed to the set temperature.

Default : 4.0 Setting range : 1.0 ~ 10.0

I : At the operation mode, press \square key once, and PE is indicated at PV display.

II : Enter the desired value by \triangle or ∇ key at SV display.

III : After entering the value, push \square key once to return to the operation mode.



Set value: 1.0 Recovery speed is fast, but overshooting becomes large.

Set value: 10.0 Recovery speed is slow, but overshooting becomes small.

6-D : Upper limit of set temperature

Set the upper limit of set temperature

Default : 500 °C Setting range : 0 ~ 500 °C

I : At the operation mode, press \bigcirc key approx.3 seconds while pressing ∇ key, and EH is indicated at PV display.

II : Push \bigcirc key 2 times, and HL is indicated at PV display.

III : Enter the desired value by \triangle key or ∇ key at SV display.

IV : After entering the value, push \bigcirc key 5 times to return to the operation mode.



6-E : Manipulated output value

Monitoring the output amount of heater

- I : At the operation mode, press \bigcirc key about 3 seconds , and operation output amount (0 ~ 100%) is indicated at SV display.
- II : Push \bigcirc key to return to the operation mode.

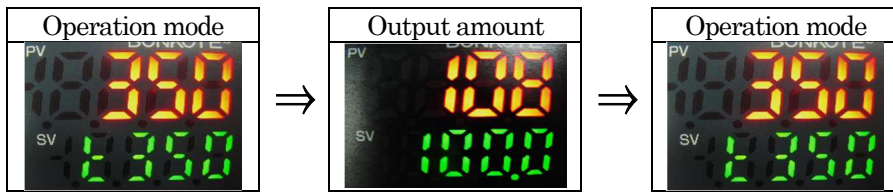

6-F : Lock function

Lock the set values to prevent error setting Default : —

- I : At the operation mode, press \bigcirc key approx. 3 seconds while pressing ∇ key.
 LOCK is indicated at PV display.
- II : Push \bigcirc key once, and LOCK-1 is indicated at PV display.
- III : Enter the desired function by \triangle key or ∇ key at SV display.
- IV : After entering the value, push \bigcirc key 6 times to return to the operation mode.

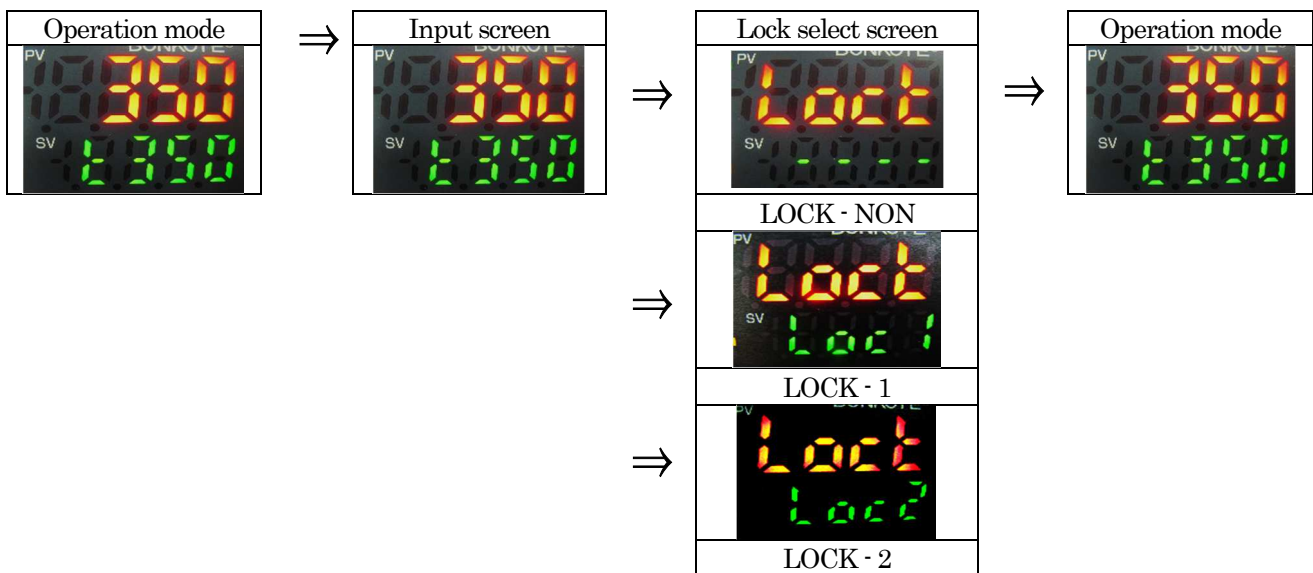

- : LOCK-NON
- LOCK : Only LOCK FUNCTION is available
- LOCK : LOCK FUNCTION and Changing set temperature are available

6-G : Anti reset wind up setting

Control the overshooting

Default : 18%

Setting range : 0 ~ 100%

- I : At the operation mode, press \bigcirc key for 3 seconds while pressing Δ key. AF is indicated at PV display.
- II : Push \bigcirc key 4 times , and $\overline{1}$ is indicated at PV display.
- III : Enter the desired value by Δ key or ∇ key at SV display.
- IV : After entering the value, push \bigcirc key 3 times to return to the operation mode.

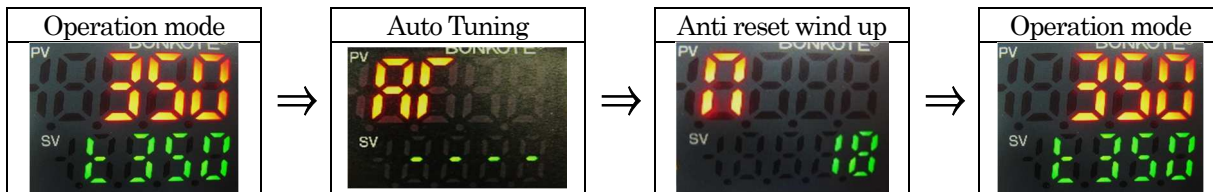

We recommend that you should keep the default. The lower value than the default can restrain overshooting, but there might be possible not to recover to the set temperature.

6-H : Auto Power Down / Auto Power Off

In order to prevent soldering iron tips from Deterioration and Oxidization, the tip temperature is lowered (Power Down), and the supplying electric power to the heater is stopped (Power Off) automatically when the tip temperature does not change for a certain period of time (User- settable). This function is not only effective for saving energy, but also for safety.

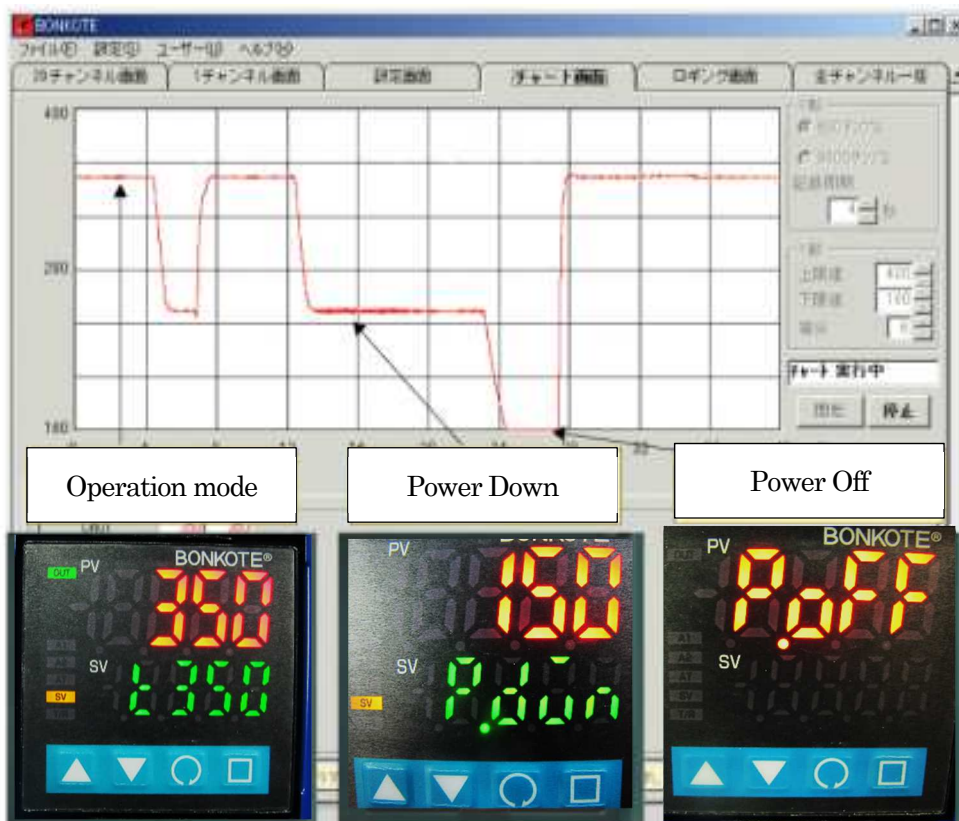

① Auto Power Down time

Default : 30 minutes

Setting range : 0 ~ 120 minutes

- I : At the operation mode, press \bigcirc key approx. 3 seconds while pressing ∇ key.
 LEP is indicated at PV display.
- II : Push \bigcirc key 4 times , and Pdt is indicated at PV display.
- III : Enter the desired value by Δ key or ∇ key at SV display.
- IV : After entering the value, push \bigcirc key 3 times to return to the operation mode.

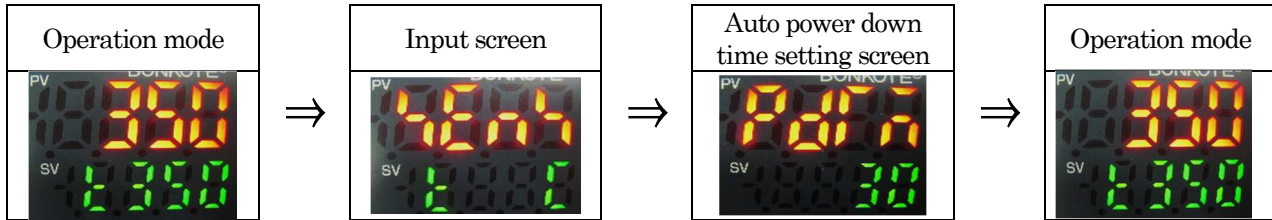

This function lowers the tip temperature automatically when the temperature is no change for more than a certain period of time you set up, since the controller recognizes that the soldering iron is inactivity. During this mode, LEP and the Auto power temperature you set up will be indicated alternately.

If unnecessary, set the value "0" (zero), and this function becomes ineffective.

② Auto Power Down temperature

Default : 150°C

Setting range : 0 ~ (set temp.) - 1°C

- I : At the operation mode, press \bigcirc key approx. 3 seconds while pressing ∇ key.
 LEP is indicated at PV display.
- II : Push \bigcirc key 5 times , and Pdt is indicated at PV display.
- III : Enter the desired value by Δ key or ∇ key at SV display.
- IV : After entering the value, push \bigcirc key 2 times to return to the operation mode.

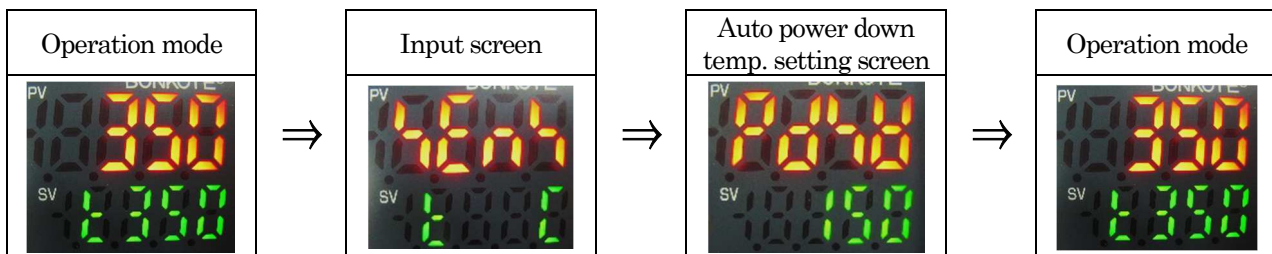

The tip temperature falls down and stands by at the specific temperature you set up.

e.g. If you set up 「150°C」 , the temperature drops and stands by around 「150°C」 when not in use. In case the operation temperature is 「350°C」 , Auto Power Down temperature can be set under 349°C only.

③ Auto Power Off time

Default : 30 minutes

Setting range : 0 ~ 120 minutes

I : At the operation mode, press \bigcirc key approx. 3 seconds while pressing ∇ key.

⏻ is indicated at PV display.

II : Push \bigcirc key 6 times, and is ⏻ indicated at PV display.

III : Enter the desired value by Δ key or ∇ key at SV display.

IV : After entering the value, push \bigcirc key once to return to the operation mode.

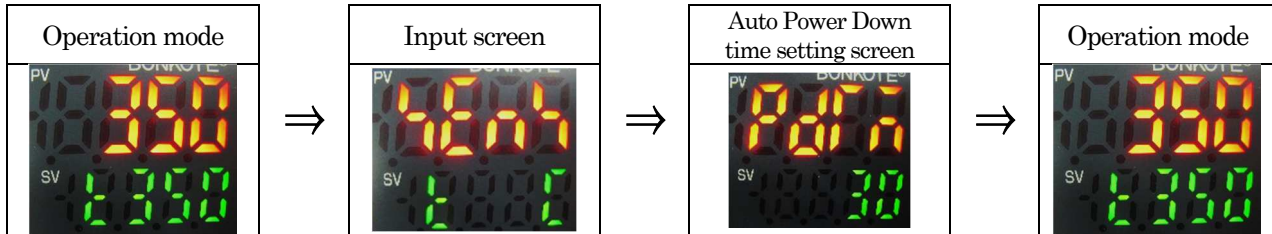

During Auto Power Down mode, ⏻ is blinking at SV display, this function turn off the power of controller automatically when the tip temperature is no change for more than a certain period of time you set up, since the controller recognizes that the soldering iron is inactivity.

If unnecessary, set the value "0" (zero), and this function becomes ineffective.

④ Exiting Auto Power Down mode

Press Δ key or ∇ key more than 3 seconds to return to the operation mode.

Temperature deviation by more than 5°C can release Auto power down mode.

e.g. Touch the iron tip with a moisturized sponge.

⑤ Exiting Auto Power Off mode

Turn on the power again.

⑥ Manual operation

After the tip temperature has reached to the set temperature, at the operation mode, press Δ key or ∇ key approx. 3 seconds to enter the power down mode.

At the power down mode, press Δ key or ∇ key approx. 3 seconds to release the mode and return to the operation mode.

6-I : PID value manual setting

M50 controller is basically unnecessary PID setting because it comes standard with Auto Tuning function. In case of Overshoot or special soldering work, you can set PID value by manual. Please use PID manual setting with your convenience.

① Proportional band

Default : 88°C Setting range : 0 ~ 1570°C (type J : 0~1200°C)

Higher set value can reduce overshoot, however, it makes temperature recovery time longer and temperature reduction during soldering work larger.

I : At the Operation mod, press \bigcirc key for 3 seconds while pressing Δ key. \overline{AF} is indicated at PV display.

II : Push \bigcirc key once, and \overline{P} is indicated at PV display.

III : Enter the desired value by Δ key or ∇ key at SV display, then push \bigcirc key 6 times to return to the operation mode.

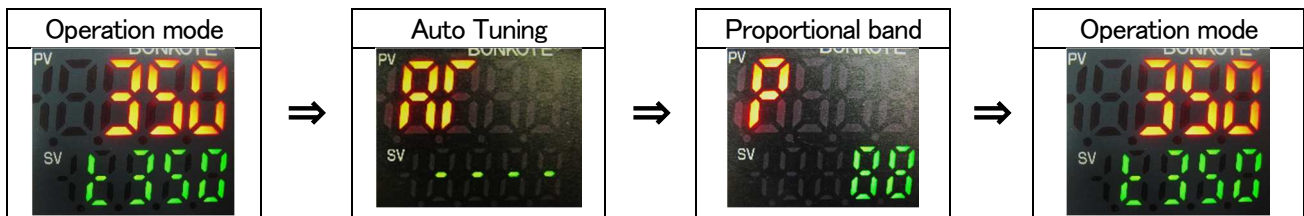

② Integration time

Default : 38 seconds Setting range : 0 ~ 3600 seconds

Higher set value can reduce overshoot, however, it makes temperature recovery time longer and temperature reduction during soldering work larger.

I : At the Operation mod, press \bigcirc key for 3 seconds while pressing Δ key. \overline{AF} is indicated at PV display.

II : Push \bigcirc key 2 times, and \overline{I} is indicated at PV display.

III : Enter the desired value by Δ key or ∇ key at SV display, then push \bigcirc key 5 times to return to the operation mode.

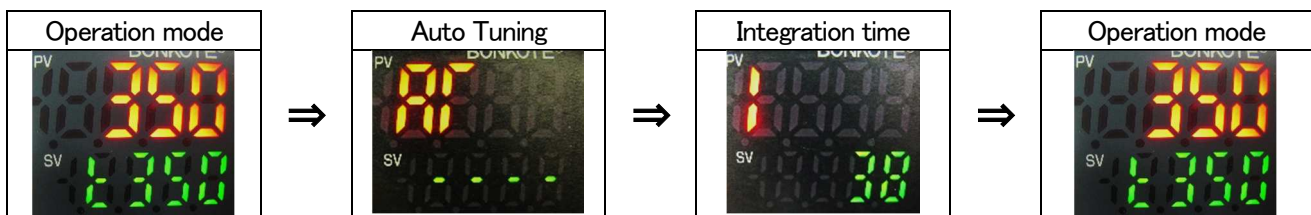

③ Derivative time

Default : 8 seconds

Setting range : 0 ~ 1800 seconds

Lower set value can reduce overshoot, however, it makes temperature recovery time longer. This value is supposed to be set or adjusted after vale “P” and “I” are almost fixed.

I : At the Operation mod, press \bigcirc key for 3 seconds while pressing Δ key. \overline{AT} is indicated at PV display.

II : Push \bigcirc key 3 times, and \overline{d} is indicated at PV display.

III : Enter the desired value by Δ key or ∇ key at SV display, then push \bigcirc key 4 times to return to the operation mode.

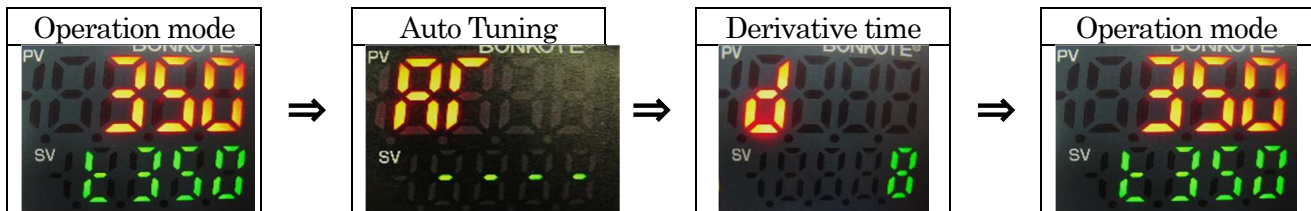

6-J : Device Number setting

Device number setting is required when you use QSS-4000 system. ※

※ Concentrated Temperature Management System

Default : 1

Setting range : 1 ~ 95

I : At the operation mode, press \bigcirc key approx. 3 seconds while pressing ∇ key. \overline{EN} is indicated at PV display.

II : Push \bigcirc key 4 times , and \overline{d} is indicated at PV display.

III : Enter the device number by Δ key or ∇ key at SV display.

IV : After entering the value, push \bigcirc key 4 times to return to the operation mode.

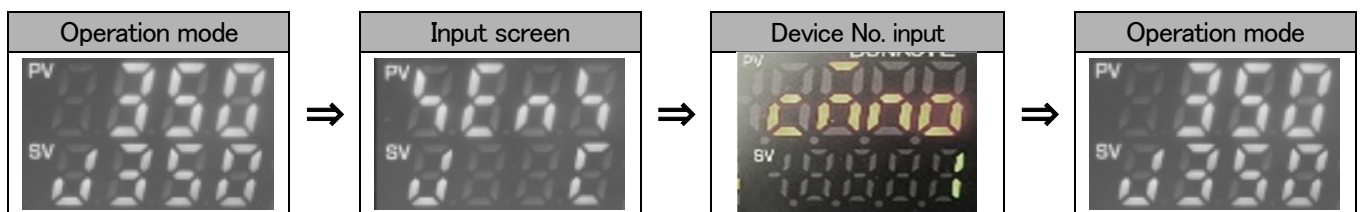

ATTENTION



The numbering must start with “1”

e.g. The first connected M50’s device number must be “1”, and 2nd one is “2” and continued

7. Character List



8. How to maintenance

How to replace a fuse



Loosen a fuse holder and remove it. Check the fuse if it needs to be replaced to a new one.

Model No.	Specification
Fuse 3A	Glass fuse 250 V 3A(φ5.2×20mm)

9. Standard specification

Input voltage	100VAC ~ 240VAC
Temperature range	0 ~ 500°C
Power cord	100VAC: 3pin 3PCHI plug cord 220VAC: 3pin 3EPV plug cord
Dimension	97 (W)×130 (D)×73 (H) mm
Weight	≦ 750 g
Fuse	3A
Temperature control method	PID control (Auto Tuning)
Temperature indication	PV display: LED (RED) SV display: LED (GREEN)
Error indication	<p>“ — — — — ” Over scale : Temperature exceed the upper limit of temperature range. ※ Error of sensors</p> <p>“ _ _ _ _ ” Under scale : Temperature exceed the lower limit of temperature range. ※ Reversed polarity of sensors</p>
Material (case)	Steel
Power consumption	≦ 10VA (controller only)

10. Guarantee and after sales service

10-A : Trouble shooting

Symptom	Probable cause	Measures	page
“— — — —” is blinking at PV display	Tip sensor is disconnected or comes off the iron unit.	Replace iron tips	
Soldering iron does not heat	※ No power to controller		
	Power cord is NOT connected with the receptacle. Power switch is NOT ON.	Check the power cord or power switch again.	P 4
	Blown fuse	Replace the fuse.	P 1 5
	※ Power is ON		
	Soldering iron and controller is NOT connected properly.	Check the connection again.	P 4
	The heater element is consumed.	Replace the heater.	
Unstable temperature	Sensor type of controller and soldering iron are NOT matched.	Match the sensor type of controller and soldering iron.	P 5
	Auto Tuning function is NOT implemented.	Implement Auto Tuning function.	P 7
	Temperature does NOT reach the set temperature.	Adjust the value of recovery speed.	P 8 P 1 0
	Overshooting is large.	Implement Anti reset wind up function.	
Key operation is unable	Lock functions are ON.	Check the lock functions.	P 9

10-B : Guarantee

Our products are shipped after sever factory tests and inspections.

However, if you find malfunctions or defects due to problems in workmanship or transportation, please contact your dealers or us.

The guarantee period of your products is in one year after your purchase, except for replacement parts.

10-C : After sales service

When you think your system does not operate properly, read this manual again to check.

If still troubles are not solved, please contact your dealers or us.

BONKOTE[®]

JAPAN BONKOTE CO., LTD.

600-14 Kasahara, Mito, Ibaraki, 310-0852 JAPAN

TEL: +81-29-241-2725

FAX: +81-29-241-2726

<http://bonkote.co.jp>

Email: info@bonkote.co.jp